

504 250

15 METERS MAXIMUM HOSE CAPACITY

FLUIDS HANDLED

- Air.
- Water.
- Antifreeze and Windshield Wash Solutions.
- High Pressure Hot Water.
- Synthetic and Mineral Oils.
- Grease.

MARKETS / APPLICATIONS

- Car and truck dealers.
- Service shops.
- Fleets.
- Lube trucks.
- Mining and construction,.
- Railroad and mass transit vehicles.
- General manufacturing.

MOUNTING

- Floor.
- Wall.
- Ceiling.
- Tank.

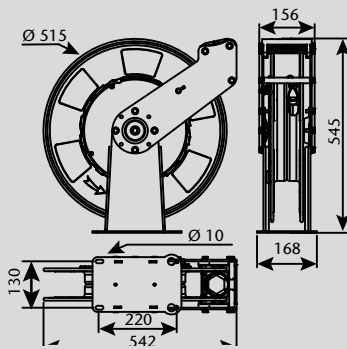

Dimensions (mm)

Full metal Intensive Duty double pedestal hose reels, with hose capacity up to 15 m x 1/2" hose.



- Very tough construction able to stand regular use and abuse in Intensive Duty applications.
- Fatigue resistant steel spring for years of durable performance and even load when pulling and recoiling the hose.
- Full port shaft and swivel for no restrictions.
- Spool mounted on two permanent lubricated and sealed ball bearings to reduce torque load on spring for smooth retraction and longer life.
- Large effective radial latching area for easier operation.
- Hose guide arm can be placed in different positions to accommodate any method of mounting.
- Narrow footprint allows accommodating more reels on the same surface.
- Hose reels with hose include 0,8 m inlet hose.

PART No.	BARE REEL	HOSE INSIDE DIAMETER	HOSE LENGTH	CONNECTING HOSE INLET	DELIVERY HOSE OUTLET	PRESSURE RATING	WEIGHT (With hose)
AIR / WATER / ANTIFREEZE SOLUTIONS							
504 150	504 159	1/2"	15 m	1/2" BSP (M)	1/2" BSP(M)	20 bar	24 kg
SYNTHETIC AND MINERAL OILS							
504 250	504 259	1/2"	15 m	1/2" BSP(M)	1/2" BSP(M)	160 bar	24 kg
GREASE AND HYDRAULIC FLUID							
504 350	504 359.001	1/4"	15 m	1/4" BSP(M)	1/4" BSP(M)	400 bar	27,5 kg
504 351	504 359	3/8"	15 m	3/8" BSP(M)	1/4" BSP(M)	400 bar	26 kg
HIGH PRESSURE HOT WATER (UP TO 100 °C)							
504 450	504 459	3/8"	15 m	3/8" BSP(M)	1/4" BSP(M)	170 bar	26 kg